

A Sickeningly Sweet Baby Boy: A Case Study on Autosomal Recessive Inheritance

by

Jacqueline Washington, Department of Biology and Chemistry, Nyack College, Nyack, NY
Anne Zayaitz, Department of Biology, Kutztown University, Kutztown, PA



Part I—Failure to Thrive

Emma and Jacob Miller were so excited at the birth of their baby Matthew.

“Jacob, he’s just so perfect! Just one problem though, it looks like he has your hairline!” Emma teased her husband who, though only 32, was balding.

“Emma, I spent all that time painting the baby’s room and I just hope that he’s not color blind like your father or he won’t be able to see it!” Jacob responded.

Both the pregnancy and delivery had been uneventful. But in the back of their minds, they really were worried because their first child, Samuel, died at the age of nine days.

By the fifth day after birth, Matthew began to have trouble nursing and by the seventh day he had completely stopped feeding. Emma and Jacob were frantic because it seemed to them that Matthew might also die.

“What is going on with our family? Another sick baby?” Jacob thought to himself.

Emma and Jacob rushed him to the emergency room. Although Mathew’s limbs were rigid and he had had a seizure, the examination showed no infection and his x-rays were normal. The doctor also did routine lab tests on his blood and urine.

“Doctor, do you think that this funny smell in Matthew’s diapers has anything to do with his problem?” Emma asked. “I brought one along so that you could smell it too.”

Questions

1. What additional information would you want to know to understand Emma and Jacob’s panic?
2. What is meant by “failure to thrive”?
3. What are some reasons why newborns fail to thrive?
4. What do you think the smell is?

Part II—Pedigree Analysis

Matthew's urine did have a sweet, maple syrup smell and lab results revealed elevated levels of the branched chain amino acids (BCAA)—valine, isoleucine, and leucine.

Skin biopsies from the baby and his parents were taken and cultured. The ability of the cultured skin fibroblasts to metabolize BCAA was determined. While his parents' enzyme activity levels were nearly normal, Matthew's was less than 2% of normal.

“Given the medical information and the smell of the urine, Matthew has Maple Syrup Urine Disease (MSUD),” reported Dr. Morton of the Clinic for Special Children. “He will not be able to breast feed or drink regular formula. What is really important is that Matthew eats a low protein diet. This diet must continue for the rest of his life or else the amino acids will accumulate in the body creating a situation that leads to brain swelling, neurological damage, and death. In spite of dietary intervention, the disease may cause several complications, the most notable being mental retardation. You need to know that dietary intervention does not cure the disease.”

Emma and Jacob were Mennonites and their family history revealed that Emma's mother had two sisters who died in their first year of life; no one knew why. Jacob's father had a sister who died at seven months of age from unknown causes. Could the gene for MSUD run in both of their families?

MSUD is due to a recessive gene. For an individual to be affected, he or she would need to inherit a defective nonworking copy from each parent. The individual would then be described as being homozygous recessive.

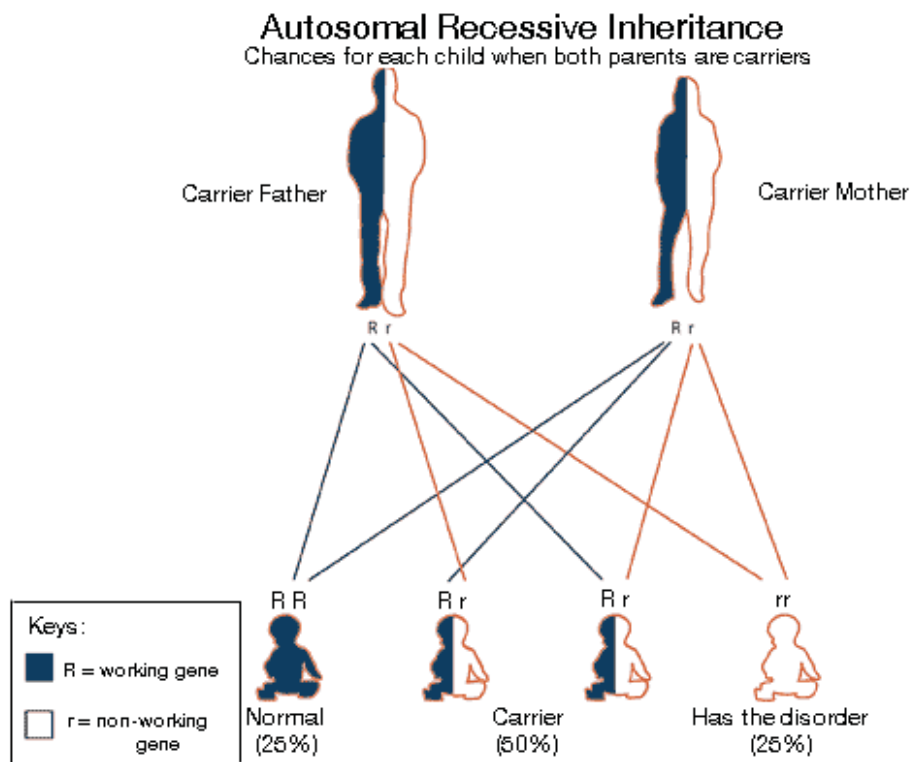

Credit: Illustration used with permission of The Screening, Technology And Research in Genetics (STAR-G) Project (<http://www.newbornscreening.info>).

Questions

Pedigree charts are useful tools used by genetic counselors to look for the incidence of disease within multiple generation families. Each generation is shown on a separate row.

1. Label the pedigree chart below to explain the relationships and the disease incidence within this family. Be sure to include Emma, Jacob, Samuel, Matthew, Emma's father, Emma's mother, Emma's aunts, Jacob's mother, Jacob's father, and Jacob's aunt.
 2. Indicate on your pedigree chart the individuals who are carriers by shading half of each circle or square.
 3. Define the terms genotype, phenotype, homozygous and heterozygous.
 4. How could their son have inherited MSUD even though neither parent suffers with it?
 5. What is the probability that they would have another affected child? A carrier?
 6. Could Emma and Jacob have children who do not have MSUD (i.e. phenotypically normal)? Explain. What is the probability?
 7. If MSUD were a dominant disorder, what would be the probability that Matthew would inherit the disease?
- ★ *Challenge Question:* Why were Emma's and Jacob's enzyme levels nearly normal?

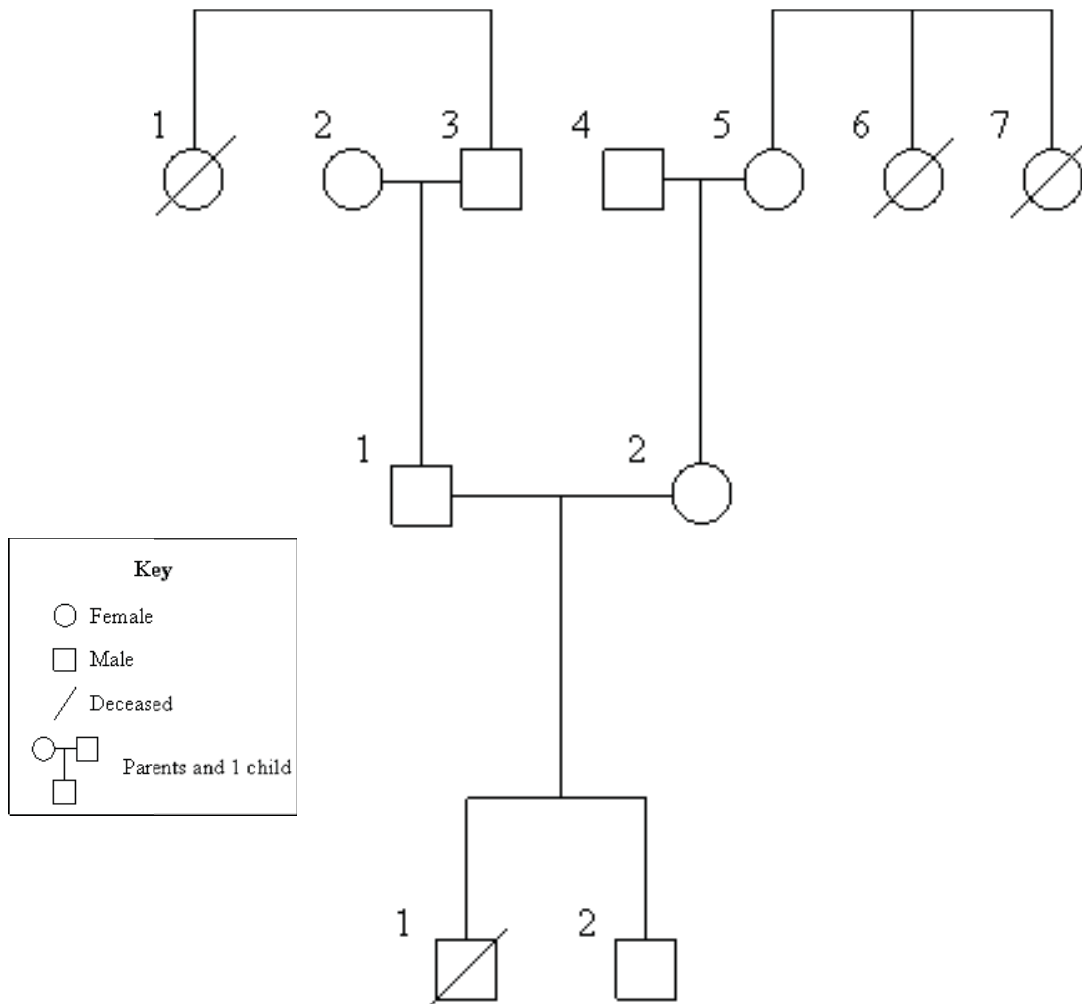

Part III—Treatment Options

Over the next four years, Matthew’s metabolism was controlled by giving him an extremely regimented low protein diet. His staple was potatoes, which he enjoyed with ketchup. He was not able to eat meat, dairy, or poultry products. Unlike most kids, Matthew never ate traditional birthday cake or ice cream.

Despite the family’s strict adherence to this MSUD diet, Matthew continued to suffer approximately three metabolic crises a year. These crises occurred when amino acids accumulated in his blood leading to the swelling of his brain. Even something as simple as a cold or the flu affected his amino acid levels and sent his metabolism into crisis.

“We cannot continue to live in constant fear that a minor infection or a simple cold or ear infection could kill our son. Even though we are doing everything we are supposed to, he is still getting sick and we are afraid we may lose Matthew,” Emma said as she dried her tears. “When I think about how we lost our first child and I see other parents of kids with MSUD grieving over the loss of their child, I’m so afraid of losing Matthew. I do not want to watch him become brain damaged or dead because of a simple sore throat or even having just one too many french fries.”

Jacob agreed. “We know that some children with MSUD have had a liver transplant and they are effectively cured. But that is major surgery and he is so small and frail. Would he survive the surgery? On the other hand, the alternative for my son is a life of uncertainty that could end in death at any moment.”

The family was directed by Dr. Morton to Children’s Hospital of Pittsburgh, where transplant experts agreed to list Matthew for a liver transplant.

Jacob and Emma learned that children who received a liver transplant would have to take strong immunosuppressive drugs for the rest of their lives. It was also clear there was a 40% possibility that Matthew could reject the liver and need a second transplant (which also might be rejected) or he could die from surgical complications.

Jacob and Emma had to decide what to do.

Questions

1. What options do these parents have for the care of their son?
2. What are the pros and cons of each choice?
3. Where would a donor liver come from?
4. MSUD is found in one newborn in 200,000 throughout the United States, but one newborn in 200 in the Amish and Mennonites of Lancaster County, Pennsylvania has the disease. Why is there such a difference in the prevalence of the disease?
5. If Matthew was your son, what would you do?



Image Credit: Photo ©iStockphoto/Amanda Rohde. Case copyright held by the [National Center for Case Study Teaching in Science](#), University at Buffalo, State University of New York. Originally published July 22, 2007. Please see our [usage guidelines](#), which outline our policy concerning permissible reproduction of this work.